

PANEL HEIGHT	PART NUMBER		PLAIN INSTRUMENT PANEL	
	FOR 19" [482.6]	FOR 24" [609.6]	A *	B *
1.75 [44.5]	20-0112-46	20-0122-46	1.72 [43.7]	-----
3.50 [88.9]	20-0312-46	20-0322-46	3.47 [88.1]	-----
5.25 [133.4]	20-0512-46	20-0522-46	5.22 [132.6]	-----
7.00 [177.8]	20-0712-46	20-0722-46	6.97 [177.0]	-----
8.75 [222.3]	20-0812-46	20-0822-46	8.72 [221.5]	-----
10.50 [266.7]	20-1012-46	20-1022-46	10.47 [265.9]	-----
12.25 [311.2]	20-1212-46	20-1222-46	12.22 [310.4]	-----
14.00 [355.6]	20-1412-46	20-1422-46	13.97 [354.8]	-----
15.75 [400.1]	20-1512-46	20-1522-46	15.72 [399.3]	-----
17.50 [444.5]	20-1712-46	20-1722-46	17.47 [443.7]	-----
19.25 [489.0]	20-1912-46	20-1922-46	19.22 [488.2]	-----
21.00 [533.4]	20-2112-46	20-2122-46	20.97 [532.6]	-----
24.50 [622.3]	20-2412-46	20-2422-46	24.47 [621.5]	7.00 [177.8]
28.00 [711.2]	20-2812-46	20-2822-46	27.97 [710.4]	8.75 [222.3]
35.00 [889.0]	20-3512-46	20-3522-46	34.97 [888.2]	10.50 [266.7]

PANEL HEIGHT	PART NUMBER		LOUVERED INSTRUMENT PANEL		
	FOR 19" [482.6]	FOR 24" [609.6]	C	D	E
7.00 [177.8]	20-0712-11	20-0722-11	2.25 [57.2]	3	5.4 [137]
8.75 [222.3]	20-0812-11	20-0822-11	3.38 [85.7]	4	7.2 [183]
10.50 [266.7]	20-1012-11	20-1022-11	5.62 [142.9]	6	10.8 [274]
12.25 [311.2]	20-1212-11	20-1222-11	6.75 [171.5]	7	12.6 [320]
14.00 [355.6]	20-1412-11	20-1422-11	9.00 [228.6]	9	16.2 [411]
15.75 [400.1]	20-1512-11	20-1522-11	10.12 [257.2]	10	18.0 [457]
17.50 [444.5]	20-1712-11	20-1722-11	12.38 [314.3]	12	21.6 [549]
19.25 [489.0]	20-1912-11	20-1922-11	13.50 [342.9]	13	23.4 [594]
21.00 [533.4]	20-2112-11	20-2122-11	15.75 [400.1]	15	27.0 [686]
24.50 [622.3]	20-2412-11	20-2422-11	19.12 [485.8]	18	32.4 [823]
28.00 [711.2]	20-2812-11	20-2822-11	22.50 [571.5]	21	37.8 [960]
35.00 [889.0]	20-3512-11	20-3522-11	30.38 [771.5]	28	50.4 [1280]

PANEL HEIGHT	PART NUMBER		GRILLED INSTRUMENT PANEL			SQUARE INCHES OPEN
	FOR 19" [482.6]	FOR 24" [609.6]	F	G	H	
7.00 [177.8]	411-107-019	411-207-019	1	3.69 [93.7]	1.64 [41.7]	39.8 [1011]
8.75 [222.3]	411-108-019	411-208-019	1	3.69 [93.7]	2.52 [63.9]	39.8 [1011]
10.50 [266.7]	411-110-019	411-210-019	1	7.12 [181.0]	1.67 [42.5]	77.0 [1956]
12.25 [311.2]	411-112-019	411-212-019	1	7.12 [181.0]	2.55 [64.7]	77.0 [1956]
14.00 [355.6]	411-114-019	411-214-019	2	3.69 [93.7]	1.64 [41.7]	79.6 [2022]
15.75 [400.1]	411-115-019	411-215-019	2	3.69 [93.7]	1.64 [41.7]	79.6 [2022]
17.50 [444.5]	411-117-019	411-217-019	1	14.34 [364.3]	1.56 [39.7]	155.0 [3937]
19.25 [489.0]	411-119-019	411-219-019	1	14.34 [364.3]	2.44 [61.9]	155.0 [3937]
21.00 [533.4]	411-121-019	411-221-019	2	7.12 [181.0]	1.64 [41.7]	154.0 [3912]
24.50 [622.3]	411-124-019	411-224-019	2	7.12 [181.0]	1.64 [41.7]	154.0 [3912]
28.00 [711.2]	411-128-019	411-228-019	2	7.12 [181.0]	1.64 [41.7]	154.0 [3912]
35.00 [889.0]	411-135-019	411-235-019	2	7.12 [181.0]	1.64 [41.7]	154.0 [3912]

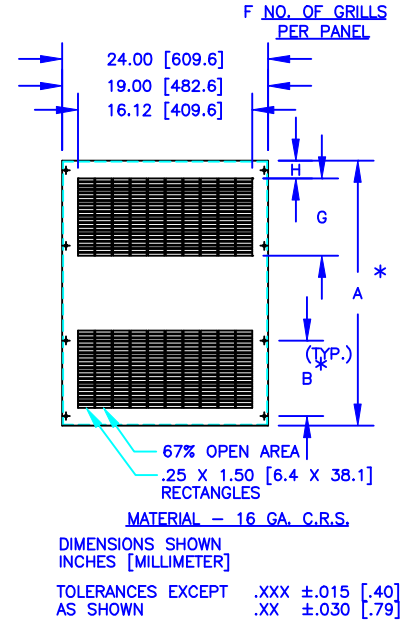
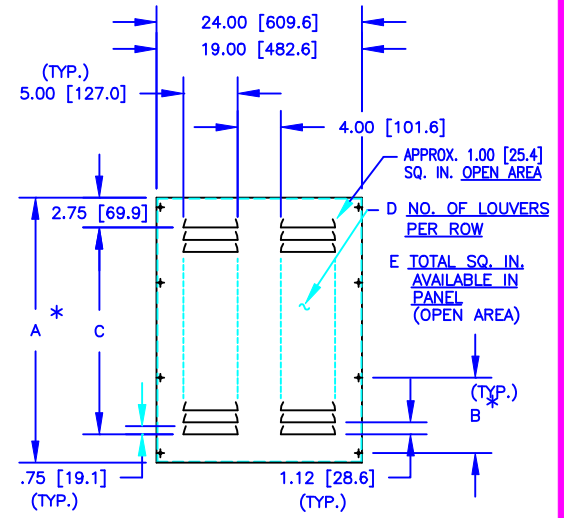
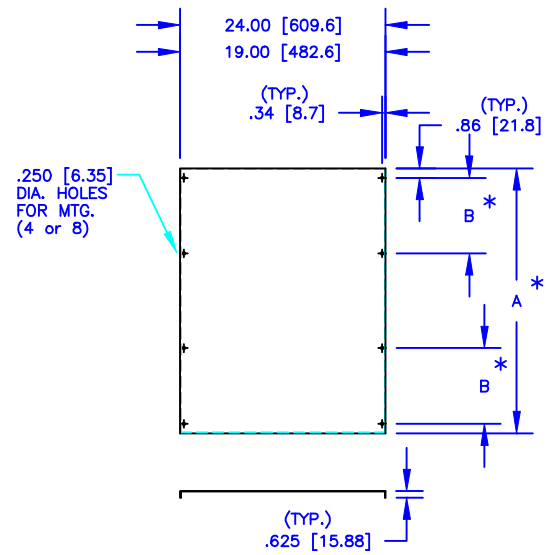

THE INVENTION, DESIGN, DETAIL AND TECHNICAL DATA SHOWN IN THIS REPRODUCTION OF ONE OF OUR PROPRIETARY ENGINEERING DRAWINGS IS THE PROPERTY OF EQUIPTO ELECTRONICS CORPORATION AND MUST BE USED SOLELY IN CONSIDERING THE PURCHASE FROM EQUIPTO ELECTRONICS CORPORATION OF THE EQUIPMENT OR MATERIAL DESCRIBED. ALL RIGHTS IN RESPECT THEREOF ARE, THRU THIS DECLARATION, EXPRESSLY RESERVED, SPECIFICALLY PRECLUDING THE COPYING IN WHOLE OR PART WITHOUT OUR WRITTEN CONSENT.

EQUIPTO ENCLOSURE SYSTEMS

INSTRUMENT PANELS, FORMED  
 19" (482.6) PANEL WIDTH  
 24" (609.6) PANEL WIDTH