

FOR USE WITH FLUSH BASES ONLY

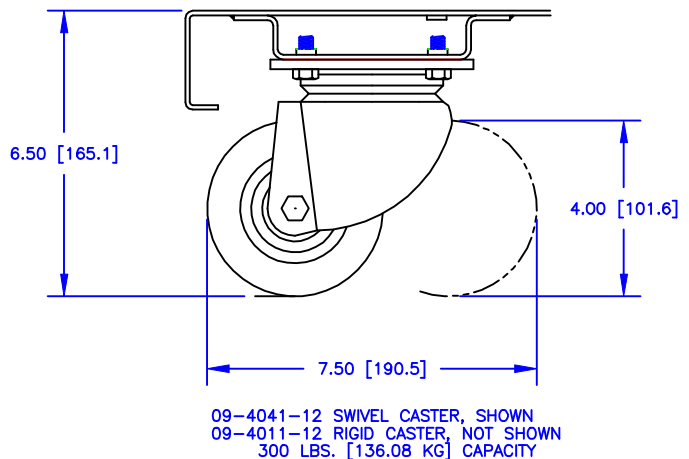
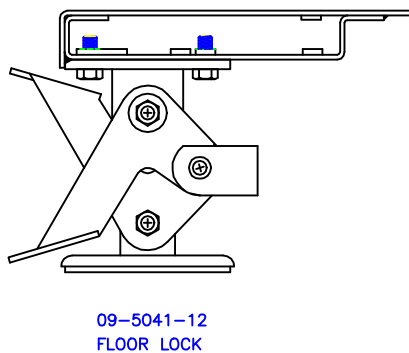

FOR USE WITH CABINET TRUCK ONLY

DIMENSIONS SHOWN
INCHES [MILLIMETER]

TOLERANCES EXCEPT
AS SHOWN .XXX ±.015 [.40]
.XX ±.030 [.79]

CASTERS & FLOOR LOCKS

THE INVENTION, DESIGN, DETAIL AND TECHNICAL DATA SHOWN IN THIS REPRODUCTION OF ONE OF OUR PROPRIETARY ENGINEERING DRAWINGS IS THE PROPERTY OF EQUIPTO ELECTRONICS CORPORATION AND MUST BE USED SOLELY IN CONSIDERING THE PURCHASE FROM EQUIPTO ELECTRONICS CORPORATION OF THE EQUIPMENT OR MATERIAL DESCRIBED. ALL RIGHTS IN RESPECT THERETO ARE, THRU THIS DECLARATION, EXPRESSLY RESERVED, SPECIFICALLY PRECLUDING THE COPYING IN WHOLE OR PART WITHOUT OUR WRITTEN CONSENT.

EQUIPTO ENCLOSURE SYSTEMS