

Introduction to Quiptron Modular Work Stations

Versatile, flexible and compatible for greater workflow efficiency

The Quiptron Modular Electronic Work Stations are designed to integrate your electronics into a functional and attractive workstation. The Quiptron design features more leg room, a wide range of tabletop widths and depths available, choice of four heights, no-sag no-sway construction. Quiptron's fine details give the customer premium quality without a premium price to pay. They include; threaded inserts in the laminated tops which prevent fasteners from working loose, Marproof panel mounting screws which prevent scratching of panels, double extension ball-bearing drawer slides, recessable mounting rails. Many colors and laminates are available.

Equipto Electronics human engineering realizes that all people are different and has developed Work Stations that are adjustable to meet these human differences. The goal is to stimulate workflow by providing more operator comfort with less fatigue. The Quiptron line of products is designed to incorporate the advantages of modular design to increase productivity. The product line includes; modular work stations, storage drawer compartments, pedestal compartments, work stations with electronic compartments, angular work stations and accessories. Please refer to Pages E14 - E18 for accessories.

The clean look, color-coordinated finishes, expandable versatility, and attention to detail of Quiptron products, gives you the personal choice to design a workflow arrangement that best meets your needs. Now you customize without paying the high cost of custom design.

The following table can help you select the best options to meet your needs. For more information on these products, please see the following pages. If you have any questions, please call (800) 204-7225.



Work Station with Electronic Compartment



Work Stations with Two Drawer Compartments



Quiptron Modular Work Stations



Work Stations with Electronic Compartments and Drawer Compartments



Angular Work Stations

Electronic Work Stations		
Stand/Work Station	Dimensions	Features and Options
Work Station with Electronic Compartment	<i>Height: 26", 29", 36", 42"</i> <i>Width: 19", 24"</i>	<ul style="list-style-type: none"> ▶ Tops have threaded inserts to prevent fasteners from becoming loose ▶ Adjustable Vertical Mounting Rails ▶ Available in 48 Standard Sizes
Work Station with Desk Compartment	<i>Height: 26", 29"</i> <i>Top Widths: 48", 63", 75"</i>	<ul style="list-style-type: none"> ▶ 2-drawer compartments have storage/file drawer to accommodate hanging folders ▶ Three drawer compartments have (3) storage drawers ▶ Drawers mounted on full extension ball bearing slides for easy access to contents ▶ Available and finished in many colors and laminates desired
Angular Work Station	<i>Height: 26", 29", 36", 42"</i> <i>Angles: 30° and 45°</i>	<ul style="list-style-type: none"> ▶ Tops have threaded inserts to prevent fasteners from becoming loose ▶ Designed to be used between any Work Station or Printer Stand in this catalog ▶ Available in 16 Standard Sizes ▶ Available and finished in many colors and laminates
Static Control		<ul style="list-style-type: none"> ▶ Static Control Table Laminate available as an option on all work stations

Quiptron Modular Work Stations

Quiptron Modular Work Stations



Work Stations and CRT Stands



Pedestal Desk Work Stations



Work Stations with Desk Compartments



Dual Operator Station with Electronic Compartments



Work Stations with two Electronic Compartments



Pedestal Electronic Work Station



Series WS1 Work Stations and CRT Stands

The Series WS1 Work Stations are designed to provide general work surfaces within configurations of other Quiptron Work Stations. Work Stations can be customized by specifying comfort edges or anti-static tops in the accessory section. Casters are also available (see page E15).

See inside back cover for standard finishes and laminates. Custom colors and laminates are also available.



Work Stations and CRT Stands

Product Features

- ▶ Tops have threaded inserts to prevent fasteners from becoming loose
- ▶ Available in five standard widths
- ▶ Available in four standard heights; 26", 29", 36" and 42"
- ▶ Available and finished in your choice of several colors and laminates

WORK STATIONS / CRT STANDS		
Depth	Width	Model No.
*For 26" Keyboard Height		
24"	24"	WS1-2424-26P
30"	24"	WS1-3024-26P
30"	36"	WS1-3036-26P
30"	48"	WS1-3048-26P
30"	60"	WS1-3060-26P
30"	72"	WS1-3072-26P
36"	24"	WS1-3624-26P
36"	36"	WS1-3636-26P
36"	48"	WS1-3648-26P
36"	60"	WS1-3660-26P
36"	72"	WS1-3672-26P

For 29" Desk Height		
Depth	Width	Model No.
24"	24"	WS1-2424-29P
30"	24"	WS1-3024-29P
30"	36"	WS1-3036-29P
30"	48"	WS1-3048-29P
30"	60"	WS1-3060-29P
30"	72"	WS1-3072-29P
36"	24"	WS1-3624-29P
36"	36"	WS1-3636-29P
36"	48"	WS1-3648-29P
36"	60"	WS1-3660-29P
36"	72"	WS1-3672-29P

* Casters add 1 1/2" to overall height

WORK STATIONS / CRT STANDS		
Depth	Width	Model No.
*For 36" Bench Height		
24"	24"	WS1-2424-36P
30"	24"	WS1-3024-36P
30"	36"	WS1-3036-36P
30"	48"	WS1-3048-36P
30"	60"	WS1-3060-36P
30"	72"	WS1-3072-36P
36"	24"	WS1-3624-36P
36"	36"	WS1-3636-36P
36"	48"	WS1-3648-36P
36"	60"	WS1-3660-36P
36"	72"	WS1-3672-36P

For 42" Counter Height		
Depth	Width	Model No.
24"	24"	WS1-2424-42P
30"	24"	WS1-3024-42P
30"	36"	WS1-3036-42P
30"	48"	WS1-3048-42P
30"	60"	WS1-3060-42P
30"	72"	WS1-3072-42P
36"	24"	WS1-3624-42P
36"	36"	WS1-3636-42P
36"	48"	WS1-3648-42P
36"	60"	WS1-3660-42P
36"	72"	WS1-3672-42P

* Casters add 1 1/2" to overall height

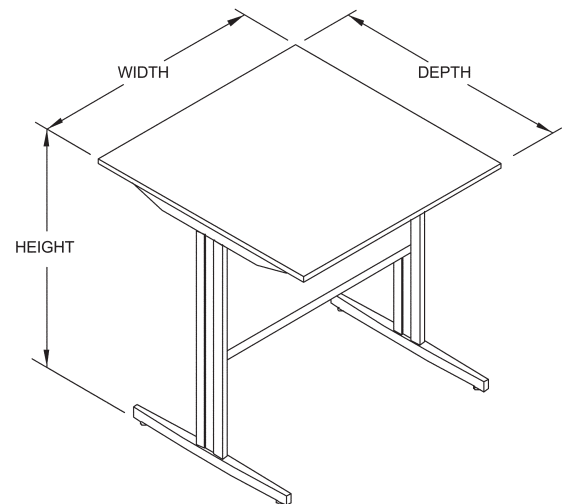

Series WS2 Pedestal Electronic Work Station

Series WS2 Work Stations are designed to provide a standalone pedestal for rack mounting equipment. Electronic compartments are furnished standard with a plain bottom panel. Grilled bottom panels are available.

Please see the accessory section to customize your work station with comfort edges or anti-static tops. Doors, panels, rear panels, casters and other accessories are also available.

See inside back cover for standard finishes and laminates. Custom colors and laminates are also available.

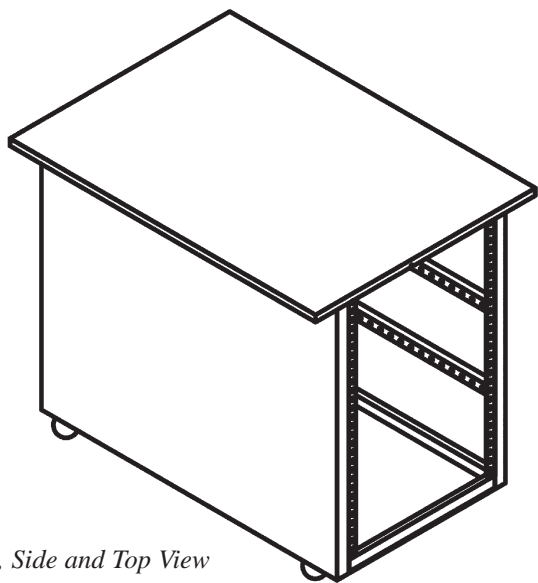

Front, Side and Top View



Pedestal Electronic Work Station

Product Features

- ▶ Tops have threaded inserts to prevent fasteners from becoming loose
- ▶ Available in two standard widths; 19" and 24"
- ▶ Available in four standard heights; 26", 29", 36" and 42"
- ▶ Available and finished in your choice of several colors and laminates

PEDESTAL ELECTRONIC WORK STATION					
Vertical Panel Space	Top Depth	Top Width	Comp. Width	Comp. Depth	Model Number
*For 26" Keyboard Height, 19 1/16" Panel Width					
21 1/16"	30"	24"	21 1/32"	25 1/2"	WS2-1925-26P
21 1/16"	36"	24"	21 1/32"	30 3/4"	WS2-1930-26P
21 1/16"	36"	24"	21 1/32"	36"	WS2-1936-26P
*For 26" Keyboard Height, 24 1/16" Panel Width					
21 1/16"	30"	30"	26 1/32"	25 1/2"	WS2-2425-26P
21 1/16"	36"	30"	26 1/32"	30 3/4"	WS2-2430-26P
21 1/16"	36"	30"	26 1/32"	36"	WS2-2436-26P
*For 29" Desk Height, 19 1/16" Panel Width					
22 7/8"	30"	24"	21 1/32"	25 1/2"	WS2-1925-29P
22 7/8"	36"	24"	21 1/32"	30 3/4"	WS2-1930-29P
22 7/8"	36"	24"	21 1/32"	36"	WS2-1936-29P
*For 29" Desk Height, 24 1/16" Panel Width					
22 7/8"	30"	30"	26 1/32"	25 1/2"	WS2-2425-29P
22 7/8"	36"	30"	26 1/32"	30 3/4"	WS2-2430-29P
22 7/8"	36"	30"	26 1/32"	36"	WS2-2436-29P

* Casters add 1 1/2" to overall height

PEDESTAL ELECTRONIC WORK STATION					
Vertical Panel Space	Top Depth	Top Width	Comp. Width	Comp. Depth	Model Number
*For 36" Bench Height, 19 1/16" Panel Width					
29 7/8"	30"	24"	21 1/32"	25 1/2"	WS2-1925-36P
29 7/8"	36"	24"	21 1/32"	30 3/4"	WS2-1930-36P
29 7/8"	36"	24"	21 1/32"	36"	WS2-1936-36P
*For 36" Bench Height, 24 1/16" Panel Width					
29 7/8"	30"	30"	26 1/32"	25 1/2"	WS2-2425-36P
29 7/8"	36"	30"	26 1/32"	30 3/4"	WS2-2430-36P
29 7/8"	36"	30"	26 1/32"	36"	WS2-2436-36P
*For 42" Counter Height, 19 1/16" Panel Width					
36 7/8"	30"	24"	21 1/32"	25 1/2"	WS2-1925-42P
36 7/8"	36"	24"	21 1/32"	30 3/4"	WS2-1930-42P
36 7/8"	36"	24"	21 1/32"	36"	WS2-1936-42P
*For 42" Counter Height, 24 1/16" Panel Width					
36 7/8"	30"	30"	26 1/32"	25 1/2"	WS2-2425-42P
36 7/8"	36"	30"	26 1/32"	30 3/4"	WS2-2430-42P
36 7/8"	36"	30"	26 1/32"	36"	WS2-2436-42P

* Casters add 1 1/2" to overall height



Series WS3 Work Station with Electronic Compartment

WS3 Work Stations feature a single electronic compartment for rack mounting equipment into your workstation. Electronic compartments can be furnished to be installed on the left or right side. (Unless otherwise specified, right hand compartments will be furnished.) *If you want the compartment installed on the left side, please change the 'WS' portion of the P/N to 'WR'.*

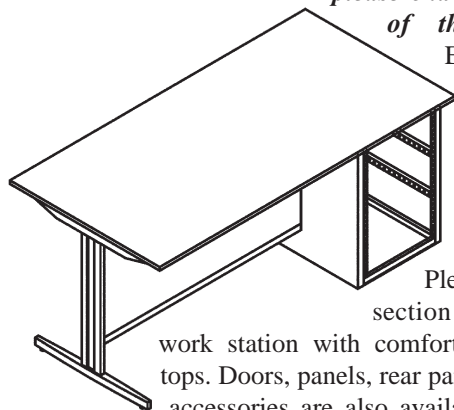

Electronic compartments are furnished standard with a plain bottom panel. Grilled bottom panels are available.

Please see the accessory section to customize your work station with comfort edges or anti-static tops. Doors, panels, rear panels, casters and other accessories are also available. See inside back cover for standard finishes and laminates. Custom colors and laminates are also available.



Work Station with Electronic Compartment

Product Features

- ▶ Tops have threaded inserts to prevent fasteners from becoming loose
- ▶ Available in four standard heights; 26", 29", 36", 42"
- ▶ Adjustable Vertical Mounting Rails

WORK STATION WITH ELECTRONIC COMPARTMENT

Vertical Panel Space	Top Depth	Top Width	Comp. Width	Comp. Depth	Knee Space	Model Number
----------------------	-----------	-----------	-------------	-------------	------------	--------------

*For 26" Keyboard Height, 19 1/16" Panel Width						
21 1/16"	30"	60"	21 1/32"	25 1/2"	28	WS3-1925-26P
21 1/16"	30"	72"	21 1/32"	25 1/2"	40	WS3-1925-26W
21 1/16"	36"	60"	21 1/32"	30 3/4"	28	WS3-1930-26P
21 1/16"	36"	72"	21 1/32"	30 3/4"	40	WS3-1930-26W
21 1/16"	36"	60"	21 1/32"	36"	28	WS3-1936-26P
21 1/16"	36"	72"	21 1/32"	36"	40	WS3-1936-26W

*For 26" Keyboard Height, 24 1/16" Panel Width						
21 1/16"	30"	60"	26 1/32"	25 1/2"	28	WS3-2425-26P
21 1/16"	30"	72"	26 1/32"	25 1/2"	40	WS3-2425-26W
21 1/16"	36"	60"	26 1/32"	30 3/4"	28	WS3-2430-26P
21 1/16"	36"	72"	26 1/32"	30 3/4"	40	WS3-2430-26W
21 1/16"	36"	60"	26 1/32"	36"	28	WS3-2436-26P
21 1/16"	36"	72"	26 1/32"	36"	40	WS3-2436-26W

*For 29" Desk Height, 19 1/16" Panel Width						
22 7/8"	30"	60"	21 1/32"	25 1/2"	28	WS3-1925-29P
22 7/8"	30"	72"	21 1/32"	25 1/2"	40	WS3-1925-29W
22 7/8"	36"	60"	21 1/32"	30 3/4"	28	WS3-1930-29P
22 7/8"	36"	72"	21 1/32"	30 3/4"	40	WS3-1930-29W
22 7/8"	36"	60"	21 1/32"	36"	28	WS3-1936-29P
22 7/8"	36"	72"	21 1/32"	36"	40	WS3-1936-29W

*For 29" Desk Height, 24 1/16" Panel Width						
22 7/8"	30"	60"	26 1/32"	25 1/2"	28	WS3-2425-29P
22 7/8"	30"	72"	26 1/32"	25 1/2"	40	WS3-2425-29W
22 7/8"	36"	60"	26 1/32"	30 3/4"	28	WS3-2430-29P
22 7/8"	36"	72"	26 1/32"	30 3/4"	40	WS3-2430-29W
22 7/8"	36"	60"	26 1/32"	36"	28	WS3-2436-29P
22 7/8"	36"	72"	26 1/32"	36"	40	WS3-2436-29W

* Casters add 1 1/2" to overall height

WORK STATION WITH ELECTRONIC COMPARTMENT

Vertical Panel Space	Top Depth	Top Width	Comp. Width	Comp. Depth	Knee Space	Model Number
----------------------	-----------	-----------	-------------	-------------	------------	--------------

*For 36" Bench Height, 19 1/16" Panel Width						
29 7/8"	30"	60"	21 1/32"	25 1/2"	28	WS3-1925-36P
29 7/8"	30"	72"	21 1/32"	25 1/2"	40	WS3-1925-36W
29 7/8"	36"	60"	21 1/32"	30 3/4"	28	WS3-1930-36P
29 7/8"	36"	72"	21 1/32"	30 3/4"	40	WS3-1930-36W
29 7/8"	36"	60"	21 1/32"	36"	28	WS3-1936-36P
29 7/8"	36"	72"	21 1/32"	36"	40	WS3-1936-36W

*For 36" Bench Height, 24 1/16" Panel Width						
29 7/8"	30"	60"	26 1/32"	25 1/2"	28	WS3-2425-36P
29 7/8"	30"	72"	26 1/32"	25 1/2"	40	WS3-2425-36W
29 7/8"	36"	60"	26 1/32"	30 3/4"	28	WS3-2430-36P
29 7/8"	36"	72"	26 1/32"	30 3/4"	40	WS3-2430-36W
29 7/8"	36"	60"	26 1/32"	36"	28	WS3-2436-36P
29 7/8"	36"	72"	26 1/32"	36"	40	WS3-2436-36W

*For 42" Counter Height, 19 1/16" Panel Width						
36 7/8"	30"	60"	21 1/32"	25 1/2"	28	WS3-1925-42P
36 7/8"	30"	72"	21 1/32"	25 1/2"	40	WS3-1925-42W
36 7/8"	36"	60"	21 1/32"	30 3/4"	28	WS3-1930-42P
36 7/8"	36"	72"	21 1/32"	30 3/4"	40	WS3-1930-42W
36 7/8"	36"	60"	21 1/32"	36"	28	WS3-1936-42P
36 7/8"	36"	72"	21 1/32"	36"	40	WS3-1936-42W

*For 42" Counter Height, 24 1/16" Panel Width						
36 7/8"	30"	60"	26 1/32"	25 1/2"	28	WS3-2425-42P
36 7/8"	30"	72"	26 1/32"	25 1/2"	40	WS3-2425-42W
36 7/8"	36"	60"	26 1/32"	30 3/4"	28	WS3-2430-42P
36 7/8"	36"	72"	26 1/32"	30 3/4"	40	WS3-2430-42W
36 7/8"	36"	60"	26 1/32"	36"	28	WS3-2436-42P
36 7/8"	36"	72"	26 1/32"	36"	40	WS3-2436-42W

Series WS4-Dual Operator Station with Electronic Compartment

WS4 Work Stations feature a single electronic compartment for rack mounting equipment into your workstation which can be shared by two operators. Electronic compartments are furnished standard with a plain bottom panel. Grilled bottom panels are available.

Please see the accessory section to customize your work station with comfort edges or anti-static tops. Doors, panels, rear panels, casters and other accessories are also available.

See inside back cover for standard finishes and laminates. Custom colors and laminates are also available.



Dual Operator Station

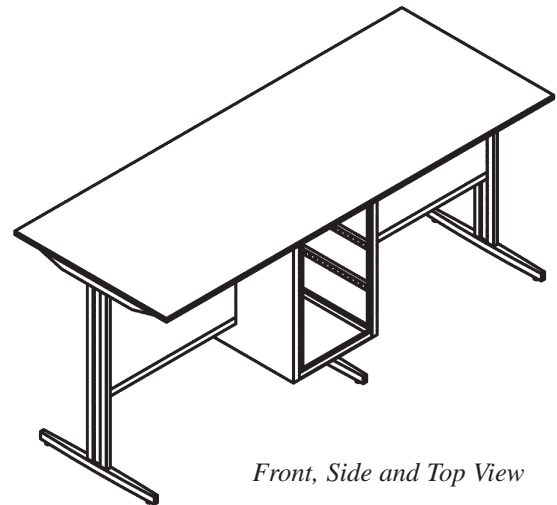

Front, Side and Top View

Product Features

- ▶ Tops have threaded inserts to prevent fasteners from becoming loose
- ▶ Available in two standard widths; 19" and 24"
- ▶ Available in four standard heights; 26", 29", 36" and 42"
- ▶ Available and finished in your choice of several colors and laminates

DUAL OPERATOR STATION With Electronic Compartment					
Vertical Panel Space	Top Depth	Top Width	Comp. Width	Comp. Depth	Model Number
*For 26" Keyboard Height, 19 1/16" Panel Width					
21 1/16"	30"	81"	21 1/32"	25 1/2"	WS4-1925-26P
21 1/16"	36"	81"	21 1/32"	30 3/4"	WS4-1930-26P
21 1/16"	36"	81"	21 1/32"	36"	WS4-1936-26P
*For 26" Keyboard Height, 24 1/16" Panel Width					
21 1/16"	30"	86"	26 1/32"	25 1/2"	WS4-2425-26P
21 1/16"	36"	86"	26 1/32"	30 3/4"	WS4-2430-26P
21 1/16"	36"	86"	26 1/32"	36"	WS4-2436-26P
*For 29" Desk Height, 19 1/16" Panel Width					
22 7/8"	30"	81"	21 1/32"	25 1/2"	WS4-1925-29P
22 7/8"	36"	81"	21 1/32"	30 3/4"	WS4-1930-29P
22 7/8"	36"	81"	21 1/32"	36"	WS4-1936-29P
*For 29" Desk Height, 24 1/16" Panel Width					
22 7/8"	30"	86"	26 1/32"	25 1/2"	WS4-2425-29P
22 7/8"	36"	86"	26 1/32"	30 3/4"	WS4-2430-29P
22 7/8"	36"	86"	26 1/32"	36"	WS4-2436-29P

* Casters add 1 1/2" to overall height

DUAL OPERATOR STATION With Electronic Compartment					
Vertical Panel Space	Top Depth	Top Width	Comp. Width	Comp. Depth	Model Number
*For 36" Bench Height, 19 1/16" Panel Width					
29 7/8"	30"	81"	21 1/32"	25 1/2"	WS4-1925-36P
29 7/8"	36"	81"	21 1/32"	30 3/4"	WS4-1930-36P
29 7/8"	36"	81"	21 1/32"	36"	WS4-1936-36P
*For 36" Bench Height, 24 1/16" Panel Width					
29 7/8"	30"	86"	26 1/32"	25 1/2"	WS4-2425-36P
29 7/8"	36"	86"	26 1/32"	30 3/4"	WS4-2430-36P
29 7/8"	36"	86"	26 1/32"	36"	WS4-2436-36P
*For 42" Counter Height, 19 1/16" Panel Width					
36 7/8"	30"	81"	21 1/32"	25 1/2"	WS4-1925-42P
36 7/8"	36"	81"	21 1/32"	30 3/4"	WS4-1930-42P
36 7/8"	36"	81"	21 1/32"	36"	WS4-1936-42P
*For 42" Counter Height, 24 1/16" Panel Width					
36 7/8"	30"	86"	26 1/32"	25 1/2"	WS4-2425-42P
36 7/8"	36"	86"	26 1/32"	30 3/4"	WS4-2430-42P
36 7/8"	36"	86"	26 1/32"	36"	WS4-2436-42P

* Casters add 1 1/2" to overall height



Series WS5-Work Station with Electronic and Drawer Compartment

WS5 Work Stations feature both an electronic compartment and a desk compartment to create an office type workstation that allows for rack mounting equipment. Electronic compartments are furnished standard with a plain bottom panel. Grilled bottom panels are available. Unless specified otherwise the drawers will come mounted on the left and the electronic compartment on the right. **If you want the compartment installed on the left side and the drawers on the right side, please change the 'WS' portion of the P/N to 'WR'.**

Please see the accessory section to customize your work station with comfort edges or anti-static tops. Doors, panels, rear panels, casters and other accessories are also available.

See inside back cover for standard finishes and laminates. Custom colors and laminates are also available.



Work Station with Electronic and Drawer Compartments

Product Features

- ▶ Tops have threaded inserts to prevent fasteners from becoming loose
- ▶ Available in two standard widths; 19" and 24"
- ▶ Available in two standard heights; 26" and 29"
- ▶ Two-drawer compartments have storage and file drawers to accommodate hanging folders
- ▶ Three drawer compartments have (3) storage drawers
- ▶ Drawers are mounted on full extension ball bearing slides for easy access to contents
- ▶ Electronic compartments come with 4 adjustable mounting rail with standard E.I.A. hole spacing
- ▶ Available and finished in your choice of several colors and laminates

WORK STATION With Electronic and Drawer Compartments						
Vertical Panel Space	Top Depth	Comp. Width	Comp. Depth	No. of Drawers	Drawer Depth	Model Number
*For 26" Keyboard Height, 19 1/16" Panel Width						
21 1/16"	30"	21 1/32"	25 1/2"	2	25 1/2"	WS5-1925-262
21 1/16"	30"	21 1/32"	25 1/2"	3	25 1/2"	WS5-1925-263
21 1/16"	36"	21 1/32"	30 3/4"	2	30 3/4"	WS5-1930-262
21 1/16"	36"	21 1/32"	30 3/4"	3	30 3/4"	WS5-1930-263
21 1/16"	36"	21 1/32"	36"	2	30 3/4"	WS5-1936-262
21 1/16"	36"	21 1/32"	36"	3	30 3/4"	WS5-1936-263
*For 26" Keyboard Height, 24 1/16" Panel Width						
21 1/16"	30"	26 1/32"	25 1/2"	2	25 1/2"	WS5-2425-262
21 1/16"	30"	26 1/32"	25 1/2"	3	25 1/2"	WS5-2425-263
21 1/16"	36"	26 1/32"	30 3/4"	2	30 3/4"	WS5-2430-262
21 1/16"	36"	26 1/32"	30 3/4"	3	30 3/4"	WS5-2430-263
21 1/16"	36"	26 1/32"	36"	2	30 3/4"	WS5-2436-262
21 1/16"	36"	26 1/32"	36"	3	30 3/4"	WS5-2436-263
*For 29" Desk Height, 19 1/16" Panel Width						
22 7/8"	30"	21 1/32"	25 1/2"	2	25 1/2"	WS5-1925-292
22 7/8"	30"	21 1/32"	25 1/2"	3	25 1/2"	WS5-1925-293
22 7/8"	36"	21 1/32"	30 3/4"	2	30 3/4"	WS5-1930-292
22 7/8"	36"	21 1/32"	30 3/4"	3	30 3/4"	WS5-1930-293
22 7/8"	36"	21 1/32"	36"	2	30 3/4"	WS5-1936-292
22 7/8"	36"	21 1/32"	36"	3	30 3/4"	WS5-1936-293
*For 29" Desk Height, 24 1/16" Panel Width						
22 7/8"	30"	26 1/32"	25 1/2"	2	25 1/2"	WS5-2425-292
22 7/8"	30"	26 1/32"	25 1/2"	3	25 1/2"	WS5-2425-293
22 7/8"	36"	26 1/32"	30 3/4"	2	30 3/4"	WS5-2430-292
22 7/8"	36"	26 1/32"	30 3/4"	3	30 3/4"	WS5-2430-293
22 7/8"	36"	26 1/32"	36"	2	30 3/4"	WS5-2436-292
22 7/8"	36"	26 1/32"	36"	3	30 3/4"	WS5-2436-293

* Casters add 1 1/2" to overall height

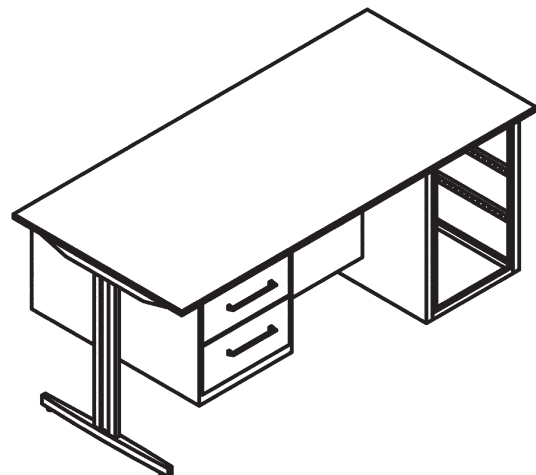

Front, Side and Top View

Series WS6-Work Station with Two Electronic Compartments

WS6 Work Stations feature two electronic compartments for rack mounting equipment into your workstation. Electronic compartments are furnished standard with a plain bottom panel. Grilled bottom panels are available.

Please see the accessory section to customize your work station with comfort edges or anti-static tops. Doors, panels, rear panels, casters and other accessories are also available.

See inside back cover for standard finishes and laminates. Custom colors and laminates are also available.

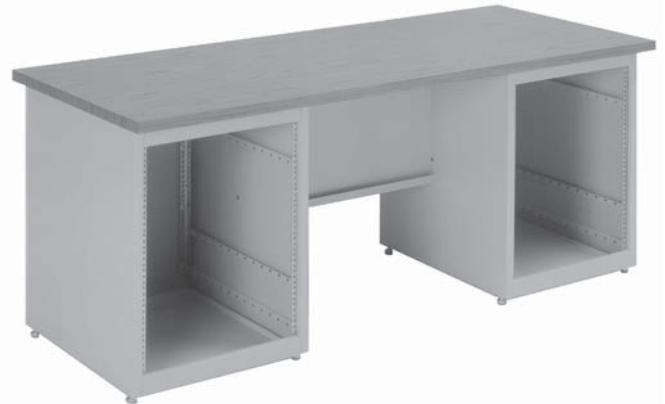

Work Station with Two Electronic Compartments

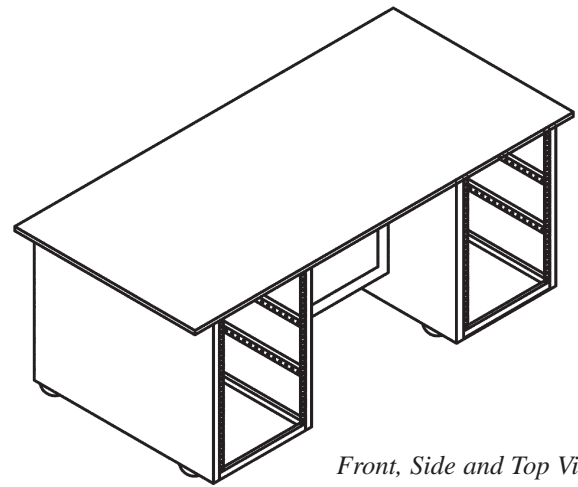

Front, Side and Top View

Product Features

- ▶ Tops have threaded inserts to prevent fasteners from becoming loose
- ▶ Available in two standard widths; 19" and 24"
- ▶ Available in four standard heights; 26", 29", 36" and 42"
- ▶ Electronic compartments come with 4 adjustable mounting rails with standard E.I.A. hole spacing
- ▶ Available and finished in your choice of several colors and laminates

WORK STATION With Two Electronic Compartments						
Vertical Panel Space	Top Depth	Top Width	Comp. Width	Comp. Depth	Desk Width	Model Number
*For 26" Keyboard Height, 19 1/16" Panel Width						
21 1/16"	30"	72"	21 1/32"	25 1/2"	70 1/16"	WS6-1925-26P
21 1/16"	36"	72"	21 1/32"	30 3/4"	70 1/16"	WS6-1930-26P
21 1/16"	36"	72"	21 1/32"	36"	70 1/16"	WS6-1936-26P
*For 26" Keyboard Height, 24 1/16" Panel Width						
21 1/16"	30"	84"	26 1/32"	25 1/2"	80 1/16"	WS6-2425-26P
21 1/16"	36"	84"	26 1/32"	30 3/4"	80 1/16"	WS6-2430-26P
21 1/16"	36"	84"	26 1/32"	36"	80 1/16"	WS6-2436-26P
*For 29" Desk Height, 19 1/16" Panel Width						
22 7/8"	30"	72"	21 1/32"	25 1/2"	70 1/16"	WS6-1925-29P
22 7/8"	36"	72"	21 1/32"	30 3/4"	70 1/16"	WS6-1930-29P
22 7/8"	36"	72"	21 1/32"	36"	70 1/16"	WS6-1936-29P
*For 29" Desk Height, 24 1/16" Panel Width						
22 7/8"	30"	84"	26 1/32"	25 1/2"	80 1/16"	WS6-2425-29P
22 7/8"	36"	84"	26 1/32"	30 3/4"	80 1/16"	WS6-2430-29P
22 7/8"	36"	84"	26 1/32"	36"	80 1/16"	WS6-2436-29P

* Casters add 1 1/2" to overall height

WORK STATION With Two Electronic Compartments						
Vertical Panel Space	Top Depth	Top Width	Comp. Width	Comp. Depth	Desk Width	Model Number
*For 36" Bench Height, 19 1/16" Panel Width						
29 7/8"	30"	72"	21 1/32"	25 1/2"	70 1/16"	WS6-1925-36P
29 7/8"	36"	72"	21 1/32"	30 3/4"	70 1/16"	WS6-1930-36P
29 7/8"	36"	72"	21 1/32"	36"	70 1/16"	WS6-1936-36P
*For 36" Bench Height, 24 1/16" Panel Width						
29 7/8"	30"	84"	26 1/32"	25 1/2"	80 1/16"	WS6-2425-36P
29 7/8"	36"	84"	26 1/32"	30 3/4"	80 1/16"	WS6-2430-36P
29 7/8"	36"	84"	26 1/32"	36"	80 1/16"	WS6-2436-36P
*For 42" Counter Height, 19 1/16" Panel Width						
36 7/8"	30"	72"	21 1/32"	25 1/2"	70 1/16"	WS6-1925-42P
36 7/8"	36"	72"	21 1/32"	30 3/4"	70 1/16"	WS6-1930-42P
36 7/8"	36"	72"	21 1/32"	36"	70 1/16"	WS6-1936-42P
*For 42" Counter Height, 24 1/16" Panel Width						
36 7/8"	30"	84"	26 1/32"	25 1/2"	80 1/16"	WS6-2425-42P
36 7/8"	36"	84"	26 1/32"	30 3/4"	80 1/16"	WS6-2430-42P
36 7/8"	36"	84"	26 1/32"	36"	80 1/16"	WS6-2436-42P

* Casters add 1 1/2" to overall height



Series WS7 Pedestal Desk Work Station

WS7 Work Stations are designed to provide a standalone pedestal with a single office desk compartment for filing or storing non-rack mount equipment.

Please see the accessory section to customize your work station with comfort edges or anti-static tops.

See inside back cover for standard finishes and laminates. Custom colors and laminates are also available.



Pedestal Desk Work Station

Product Features

- ▶ Tops have threaded inserts to prevent fasteners from becoming loose
- ▶ Available in two standard heights; 26" and 29"
- ▶ Two-drawer compartments have a storage and file drawer to accommodate hanging folders
- ▶ Three drawer compartments have (3) storage drawers
- ▶ Drawers are mounted on full extension ball bearing slides for easy access to contents
- ▶ Available and finished in your choice of several colors and laminates

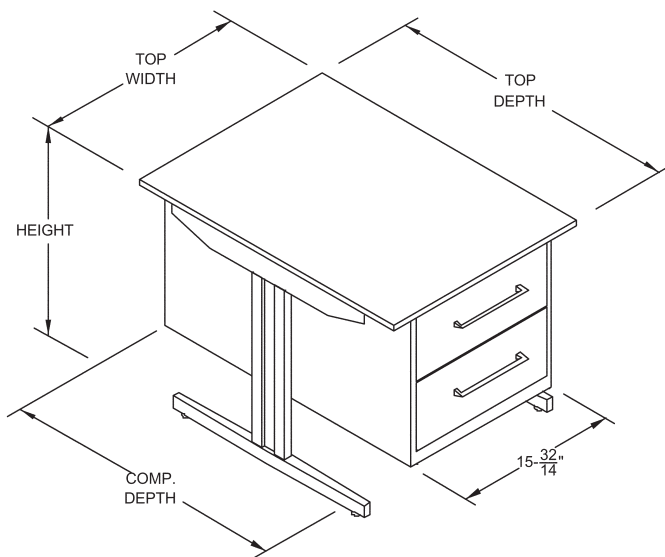

Pedestal Desk Work Station with size dimensions

PEDESTAL DESK WORK STATION			
Top Depth	Comp. Depth	No. of Drawers	Model Number
*For 26" Keyboard Height			
30"	25 1/2"	2	WS7-3024-262
30"	25 1/2"	3	WS7-3024-263
36"	30 3/4"	2	WS7-3624-262
36"	30 3/4"	3	WS7-3624-263
*For 29" Desk Height			
30"	25 1/2"	2	WS7-3024-292
30"	25 1/2"	3	WS7-3024-293
36"	30 3/4"	2	WS7-3624-292
36"	30 3/4"	3	WS7-3624-293

* Casters add 1 1/2" to overall height

Series WS8-Work Station with Desk Compartment

WS8 Work Stations feature a single desk compartment for filing or storing non-rack mount equipment. Desk compartments can be furnished to be installed on the left or right side. *If you want the compartment installed on the left side, please change the 'WS' portion of the P/N to 'WR'.* (Unless otherwise specified, right hand compartments will be furnished.)

Please see the accessory section to customize your work station with comfort edges or anti-static tops.

See inside back cover for standard finishes and laminates. Custom colors and laminates are also available.



Work Station with Desk Compartment

Product Features

- ▶ Tops have threaded inserts to prevent fasteners from becoming loose
- ▶ Available in two standard heights; 26" and 29"
- ▶ Two-drawer compartments have a storage and file drawer to accommodate hanging folders
- ▶ Three drawer compartments have (3) storage drawers
- ▶ Drawers are mounted on full extension ball bearing slides for easy access to contents
- ▶ Available and finished in your choice of several colors and laminates

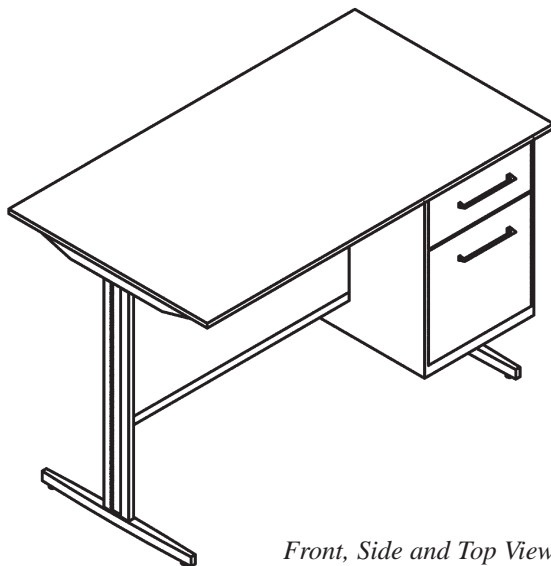

Front, Side and Top View

WORK STATION With Desk Compartment					
Top Depth	Top Width	Knee Space	No. of Drawers	Comp. Depth	Model Number
*For 26" Keyboard Height					
30"	48"	28"	2	25 1/2"	WS8-3048-262
30"	48"	28"	3	25 1/2"	WS8-3048-263
36"	48"	28"	2	30 3/4"	WS8-3648-262
36"	48"	28"	3	30 3/4"	WS8-3648-263
30"	63"	40"	2	25 1/2"	WS8-3063-262
30"	63"	40"	3	25 1/2"	WS8-3063-263
36"	63"	40"	2	30 3/4"	WS8-3663-262
36"	63"	40"	3	30 3/4"	WS8-3663-263
30"	75"	52"	2	25 1/2"	WS8-3075-262
30"	75"	52"	3	25 1/2"	WS8-3075-263
36"	75"	52"	2	30 3/4"	WS8-3675-262
36"	75"	52"	3	30 3/4"	WS8-3675-263
*For 29" Desk Height					
30"	48"	28"	2	25 1/2"	WS8-3048-292
30"	48"	28"	3	25 1/2"	WS8-3048-293
36"	48"	28"	2	30 3/4"	WS8-3648-292
36"	48"	28"	3	30 3/4"	WS8-3648-293
30"	63"	40"	2	25 1/2"	WS8-3063-292
30"	63"	40"	3	25 1/2"	WS8-3063-293
36"	63"	40"	2	30 3/4"	WS8-3663-292
36"	63"	40"	3	30 3/4"	WS8-3663-293
30"	75"	52"	2	25 1/2"	WS8-3075-292
30"	75"	52"	3	25 1/2"	WS8-3075-293
36"	75"	52"	2	30 3/4"	WS8-3675-292
36"	75"	52"	3	30 3/4"	WS8-3675-293

* Casters add 1 1/2" to overall height



Series WS9-Work Stations with Two Drawer Compartments

WS9 Work Stations feature two desk compartments for filing or storing non-rack mount equipment. The compartments come installed as shown in the picture to the right. *If you would like the compartments reversed (3 drawers on the left side and 2 drawers on the right side) then please change the 'WS' portion of the P/N to 'WR'.*

Please see the accessory section to customize your work station with comfort edges or anti-static tops.

See inside back cover for standard finishes and laminates. Custom colors and laminates are also available.



*Work Station
with Two Drawer Compartments*

Product Features

- ▶ Tops have threaded inserts to prevent fasteners from becoming loose
- ▶ Available in two standard heights; 26" and 29"
- ▶ Two-drawer compartments have a storage and file drawer to accommodate hanging folders
- ▶ Three drawer compartments have (3) storage drawers
- ▶ Drawers are mounted on full extension ball bearing slides for easy access to contents
- ▶ Available and finished in your choice of several colors and laminates

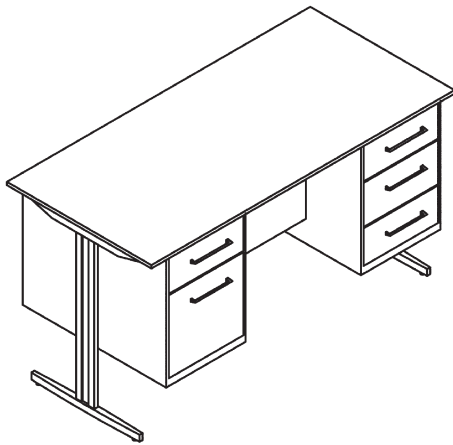

*Work Station
with size dimensions*

WORK STATIONS With Two Drawer Compartments			
Height*	Top Depth	Comp. Depth	Model Number
26"	30"	25 1/2"	WS9-3072-26P
26"	36"	30 3/4"	WS9-3672-26P WS9-
29"	30"	25 1/2"	3072-29P
29"	36"	30 3/4"	WS9-3672-29P

* Casters add 1 1/2" to overall height

Series AW1 Angular Work Station

AW1 Angular Work Stations are designed to be used between any Work Station or Printer Stand in this catalog to create custom work station arrangements.

Please see the accessory section to customize your work station with comfort edges or anti-static tops.

See inside back cover for standard finishes and laminates. Custom colors and laminates are also available.

Product Features

- ▶ Tops have threaded inserts to prevent fasteners from becoming loose
- ▶ Available in 30° and 45° angles
- ▶ Available in four standard heights; 26", 29", 36" and 42"
- ▶ Available and finished in your choice of several colors and laminates desired



Angular Work Station

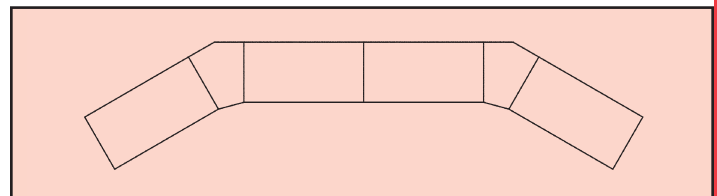

Typical desk arrangement
using two 30° angular desks

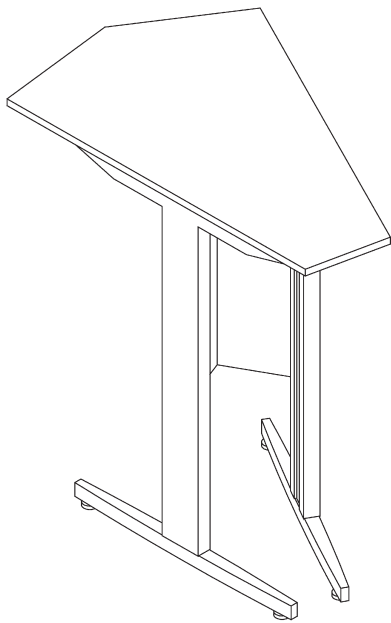

Front, Side and Top View

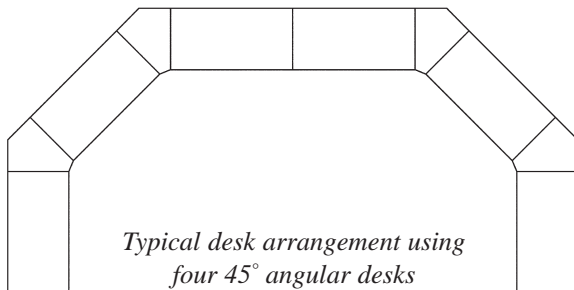

Typical desk arrangement using
four 45° angular desks

ANGULAR WORK STATION				
Angle	Depth	Front	Rear	Model No.
*For 26" Keyboard Height				
30°	30"	10 33/64"	13 15/32"	AW1-3030-26P
30°	36"	8 31/32"	14 9/32"	AW1-3036-26P
45°	30"	5 15/32"	15 25/64"	AW1-4530-26P
45°	36"	3 11/64"	16 5/8"	AW1-4536-26P
*For 29" Desk Height				
30°	30"	10 33/64"	13 15/32"	AW1-3030-29P
30°	36"	8 31/32"	14 9/32"	AW1-3036-29P
45°	30"	5 15/32"	15 25/64"	AW1-4530-29P
45°	36"	3 11/64"	16 5/8"	AW1-4536-29P
*For 36" Bench Height				
30°	30"	10 33/64"	13 15/32"	AW1-3030-36P
30°	36"	8 31/32"	14 9/32"	AW1-3036-36P
45°	30"	5 15/32"	15 25/64"	AW1-4530-36P
45°	36"	3 11/64"	16 5/8"	AW1-4536-36P
*For 42" Counter Height				
30°	30"	10 33/64"	13 15/32"	AW1-3030-42P
30°	36"	8 31/32"	14 9/32"	AW1-3036-42P
45°	30"	5 15/32"	15 25/64"	AW1-4530-42P
45°	36"	3 11/64"	16 5/8"	AW1-4536-42P

* Casters add 1 1/2" to overall height



Electronic Compartment Doors/ Accessories

Electronic Compartment Doors

When ordering the Equipto Electronic Compartment Doors, please specify whether doors are to be mounted in the front or the rear.

Product Features

- ▶ Heavy 16-gauge steel construction
- ▶ Instantly removable by retractable, spring-loaded hinge pins
- ▶ Chrome and Black vinyl, modern-design door handles
- ▶ Hidden magnetic latching
- ▶ Mountable front, rear or both



OS-0612-GC

Outlet Strip

The Equipto Outlet Strip is a wired, heavy duty 6 outlet strip with switch and UL approved components. The long-lasting indicator lamp denotes "power-on". The box contains a 15 amp circuit breaker with a 12' long 3-wire grounded service cord.

Electronic Compartment Doors			
Part Number*	Panel Height	Right or Left	Plain or Louvered
For 19" wide panel space			
CD-1419-__	14"	R or L	P or L
CD-1719-__	17 1/2"	R or L	P or L
CD-2119-__	21"	R or L	P or L
CD-2219-__	22 3/4"	R or L	P or L
CD-2919-__	29 3/4"	R or L	P or L
CD-3619-__	36 3/4"	R or L	P or L
For 24" wide panel space			
CD-1424-__	14"	R or L	P or L
CD-1724-__	17 1/2"	R or L	P or L
CD-2124-__	21"	R or L	P or L
CD-2224-__	22 3/4"	R or L	P or L
CD-2924-__	29 3/4"	R or L	P or L
CD-3624-__	36 3/4"	R or L	P or L

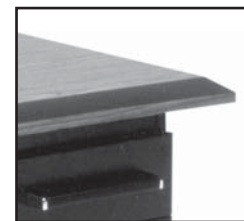

Comfort Edges

Comfort Edges can be added to the front edge of any work station to eliminate operator fatigue from sharp edges cutting off the circulation. Comfort edges can be ordered in the same laminate color as the top or contrasting color such as black. To order, specify in the description and add "-CE" to part number. Available in off-white standard color.

Example: WS1-3060-26P-CE work station with comfort edge.

* To specify, add hand (R / L) and style (P / L) to part number. If lock is required, add "-LK" suffix. When ordering, specify mount in the front or rear.

Static Control

Static Control Laminate is a decorative, clean melamine which rapidly dissipates static electrical charges and is suitable for clean room use. It is recommended for use in work areas which must be free of static electrical charges. Chemical and heat resistance is equivalent to that of non-conductive laminates.

When static charge items are placed on the laminate their charge is removed. No suppressed voltages reappear when the items are removed from the laminate surface. Each table top comes with a grounding kit and a 10' long ground cord with a one megohm resistor. You may order this product with the work station.

Product Features

- ▶ Surface resistivity of 10^6 to 10^9 ohms/sq. is standard. Other resistivities are available
- ▶ Dissipates a 5000 volt static charge in less than 0.05 seconds at 50% relative humidity.

Equipment & Storage Drawers Pencil Drawers/Accessories

Equipment and Storage Drawers

Equipment and Storage drawers are designed to house test equipment, cables, accessories and other operational gear. The drawers ride on ball bearing extension slides having front disconnect. The drawer pulls are flush mounted with recessed finger grip.

Product Features

- ▶ Constructed of 20-gauge steel
- ▶ Available in 6 drawer heights
- ▶ Available in 25 1/2", 30 3/4", and 36" depths

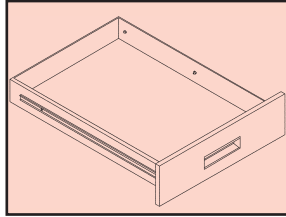

Pencil Drawers

Product Features

- ▶ Heavy Gauge Construction
- ▶ Curved Pencil Trough
- ▶ Adequate room for 8 1/2" x 11" pads
- ▶ Ball Bearing Slides with Front Disconnect

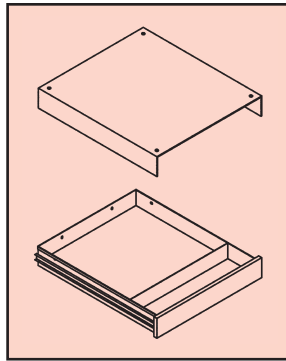

QPD-2800-000

Mar-Proof Screws

For *punched* Panel Mounting Angles. Screw 10B x 1 1/8" (80-0201-05) is used with 5/8" formed panels, while 10B x 5/8" (80-02020-5) is used with 1/8" flat panels. Screws and Speed Nuts® (80-0401-03) have Zinc Plating with Trivalent Chromium Passivation.

If *tapped* Vertical Mounting Rails are used, 5/8" Formed Instrument Panels are fastened to the mounting angles with 10-32 x 1" (80-0101-05) Phillips Head machine screws. 1/8" Flat Panels are fastened with 10-32 x 1/3" (80-0102-05) machine screws. Both screws have Mar-Proof recessed black nylon washers.

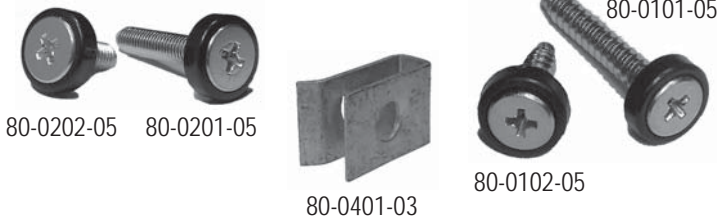

EQUIPMENT & STORAGE DRAWERS		
Height of Drawer Front	19" Panel Width	24" Panel Width
For frames with a 25 1/2" depth		
3 1/2"	14-0313-11	14-0323-11
5 1/4"	14-0513-11	14-0523-11
7"	14-0713-11	14-0723-11
8 3/4"	14-0813-11	14-0823-11
10 1/2"	14-1013-11	14-1023-11
14"	14-1413-11	14-1423-11
For frames with a 30 3/4" depth		
3 1/2"	14-0314-11	14-0324-11
5 1/4"	14-0514-11	14-0524-11
7"	14-0714-11	14-0724-11
8 3/4"	14-0814-11	14-0824-11
10 1/2"	14-1014-11	14-1024-11
14"	14-1414-11	14-1424-11
For frames with a 36" depth		
3 1/2"	14-0315-11	14-0325-11
5 1/4"	14-0515-11	14-0525-11
7"	14-0715-11	14-0725-11
8 3/4"	14-0815-11	14-0825-11
10 1/2"	14-1015-11	14-1025-11
14"	14-1415-11	14-1425-11

Casters

Quipton Casters provide great mobility with a twin wheel design. They are constructed of a sturdy bright chrome-plated die-cast hood with nylon wheels. Each caster has a mobility load rating of 75 lbs. and will add 1 1/2" to overall height. If you require Casters, please specify as follows:

- Plain**—EDC-0275-BCP
- Locking**—EDC-0275-BCL



Where the combined weight of desk and equipment exceeds 400 lbs., the Heavy Duty Swivel Caster should be used. The rated load capacity is 210 lbs. per caster. The Heavy Duty caster will add 3" to overall height of desk.

- Swivel without lock**—PC-1213-SP
- Swivel locking**—PC-1213-SL



*Add "—HD" suffix to desk part number



5/8" Formed Instrument Panels

5/8" Formed Instrument Panels

All of the Equipto Formed Instrument Panels are constructed 5/8" thick with a single flange. They mount directly to the Panel Mounting Angles, usually with sheet metal screws, with Mar-proof black nylon washers and Speed Nuts®, flush with the cabinet frame. Plain Formed Instrument Panels are available in nineteen heights. Louvered Panels are not available in heights less than 7", because the amount of square inches available are not sufficient to be practical. All Formed Instrument Panels are available in 19" and 24" panel widths.

Product Features

- ▶ Constructed of 16-gauge steel
- ▶ Available Plain or Louvered formed
- ▶ Available in 19" and 24" panel widths
- ▶ Perforated are constructed of 18-gauge steel
- ▶ Completely perforated with 1/16" diameter holes on staggered 7/64" centers

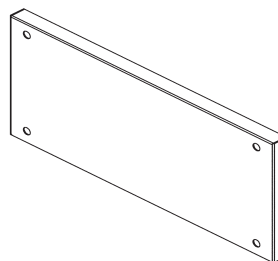

Plain Formed Instrument Panels available in 19 heights and 2 widths

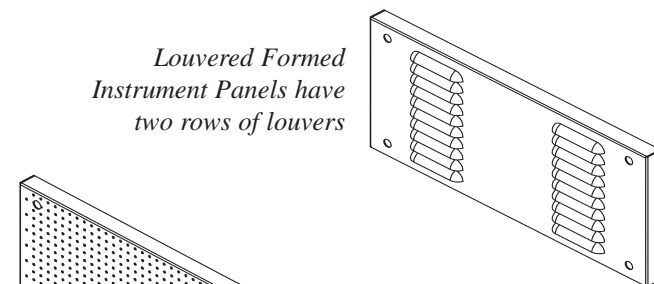

Louvered Formed Instrument Panels have two rows of louvers

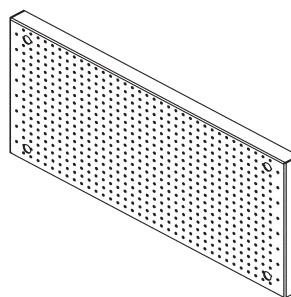

Perforated panels are ideal for releasing heat and complying with codes restricting size of openings

5/8" FORMED INSTRUMENT PANELS

For Front, Rear, Filler, Instrument, or Top Panels

Height of Panel	Plain		Perforated		Louvered Fully		Louvered Top Only		Louvered Bottom Only		Louvered Top & Bottom	
	19" Width	24" Width	19" Width	24" Width	19" Width	24" Width	19" Width	24" Width	19" Width	24" Width	19" Width	24" Width
1 3/4"	20-0112-46	20-0122-46										
3 1/2"	20-0312-46	20-0322-46	20-0312-31	20-0322-31								
5 1/4"	20-0512-46	20-0522-46	20-0512-31	20-0522-31								
7"	20-0712-46	20-0722-46	20-0712-31	20-0722-31	20-0712-11	20-0722-11						
8 3/4"	20-0812-46	20-0822-46	20-0812-31	20-0822-31	20-0812-11	20-0822-11						
10 1/2"	20-1012-46	20-1022-46	20-1012-31	20-1022-31	20-1012-11	20-1022-11						
12 1/4"	20-1212-46	20-1222-46	20-1212-31	20-1222-31	20-1212-11	20-1222-11						
14"	20-1412-46	20-1422-46	20-1412-31	20-1422-31	20-1412-11	20-1422-11	20-1412-12	20-1422-12	20-1412-13	20-1422-13	20-1412-14	20-1422-14
15 3/4"	20-1512-46	20-1522-46	20-1512-31	20-1522-31	20-1512-11	20-1522-11	20-1512-12	20-1522-12	20-1512-13	20-1522-13	20-1512-14	20-1522-14
17 1/2"	20-1712-46	20-1722-46	20-1712-31	20-1722-31	20-1712-11	20-1722-11	20-1712-12	20-1722-12	20-1712-13	20-1722-13	20-1712-14	20-1722-14
19 1/4"	20-1912-46	20-1922-46	20-1912-31	20-1922-31	20-1912-11	20-1922-11	20-1912-12	20-1922-12	20-1912-13	20-1922-13	20-1912-14	20-1922-14
21"	20-2112-46	20-2122-46	20-2112-31	20-2122-31	20-2112-11	20-2122-11	20-2112-12	20-2122-12	20-2112-13	20-2122-13	20-2112-14	20-2122-14
22 3/4"	20-2212-46	20-2222-46	20-2212-31	20-2222-31	20-2212-11	20-2222-11	20-2212-12	20-2222-12	20-2212-13	20-2222-13	20-2212-14	20-2222-14
24 1/2"	20-2412-46	20-2422-46	20-2412-31	20-2422-31	20-2412-11	20-2422-11	20-2412-12	20-2422-12	20-2412-13	20-2422-13	20-2412-14	20-2422-14
26 1/4"	20-2612-46	20-2622-46	20-2612-31	20-2622-31	20-2612-11	20-2622-11	20-2612-12	20-2622-12	20-2612-13	20-2622-13	20-2612-14	20-2622-14
28"	20-2812-46	20-2822-46	20-2812-31	20-2822-31	20-2812-11	20-2822-11	20-2812-12	20-2822-12	20-2812-13	20-2822-13	20-2812-14	20-2822-14
29 3/4"	20-2912-46	20-2922-46			20-2912-11	20-2922-11	20-2912-12	20-2922-12	20-2912-13	20-2922-13	20-2912-14	20-2922-14
35"	20-3512-46	20-3522-46			20-3512-11	20-3522-11	20-3512-12	20-3522-12	20-3512-13	20-3522-13	20-3512-14	20-3522-14
36 3/4"	20-3612-46	20-3622-46			20-3612-11	20-3622-11	20-3612-12	20-3622-12	20-3612-13	20-3622-13	20-3612-14	20-3622-14

If mounting to punched vertical mtg rails, add a 'C' prefix to panel P/N Example: C20-0112-46

If mounting to tapped vertical mtg rails, add a 'T' prefix to panel P/N Example: T20-0112-46

1/8" Thick Instrument Panels/ Panel Shims/Panel Mounting Angles

1/8" Thick Flat Instrument Panels

The Equipto Thick Flat Instrument Panels are available in 1/8" thick steel or aluminum. They are punched for E.I.A. Universal Standard RS-310 hole spacing.

The Instrument panels are fastened with 10B Phillips Head sheet metal screws, using Mar-Proof recessed black nylon washers and Speed Nuts®. Flat Plate Instrument Panels are usually shipped attached to the cabinet frame in the locations specified.

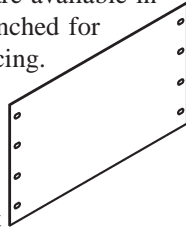

1/8" THICK FLAT PLATE INSTRUMENT PANELS				
Height of Flat Panel	Steel Panels		Aluminum Panels	
	19" Panel Width	24" Panel Width	19" Panel Width	24" Panel Width
	Part No.	Part No.	Part No.	Part No.
1 3/4"	21-0112-1_*	21-0122-1_*	21-0112-4_*	21-0122-4_*
3 1/2"	21-0312-1_*	21-0322-1_*	21-0312-4_*	21-0322-4_*
5 1/4"	21-0512-1_*	21-0522-1_*	21-0512-4_*	21-0522-4_*
7"	21-0712-1_*	21-0722-1_*	21-0712-4_*	21-0722-4_*
8 3/4"	21-0812-1_*	21-0822-1_*	21-0812-4_*	21-0822-4_*
10 1/2"	21-1012-1_*	21-1022-1_*	21-1012-4_*	21-1022-4_*
12 1/4"	21-1212-1_*	21-1222-1_*	21-1212-4_*	21-1222-4_*
14"	21-1412-1_*	21-1422-1_*	21-1412-4_*	21-1422-4_*
15 3/4"	21-1512-1_*	21-1522-1_*	21-1512-4_*	21-1522-4_*
17 1/2"	21-1712-1_*	21-1722-1_*	21-1712-4_*	21-1722-4_*
19 1/4"	21-1912-1_*	21-1922-1_*	21-1912-4_*	21-1922-4_*
21"	21-2112-1_*	21-2122-1_*	21-2112-4_*	21-2122-4_*
22 3/4"	21-2212-1_*	21-2222-1_*	21-2212-4_*	21-2222-4_*
24 1/2"	21-2412-1_*	21-2422-1_*	21-2412-4_*	21-2422-4_*
26 1/4"	21-2612-1_*	21-2622-1_*	21-2612-4_*	21-2622-4_*
28"	21-2812-1_*	21-2822-1_*	21-2812-4_*	21-2822-4_*

*Complete the last digit of the panel P/N with one of the following choices:

2	w/hdwe for punched vertical mtg rails in desk
4	w/hdwe for tapped vertical mtg rails in desk
6	w/hdwe for shims & punched vertical mtg rails in desk
8	w/hdwe for shims & tapped vertical mtg rails in desk

Vertical Mounting Rails

All of Equipto's Electronic Compartments are supplied with four vertical mounting rails, two are located at the front and two at the rear of the compartment. You may require additional rails or you may substitute tapped rails for punched rails. Please see the table below to select the part number of the vertical mountings you need to fit the electronic compartment you are using. The rails are furnished plated.

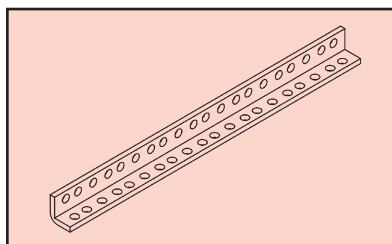

Visit our web site at www.equiptoelec.com for the latest technical data or a price quote

Panel Shims

Panel Shims are constructed of 16-gauge cold rolled steel formed into a "U" shaped channel. They are used to bring flat panels into alignment with the face of the formed panels when Flat Plate Instrument Panels are used in combination with 5/8" Formed Instrument Panels in the same panel area. They are usually shipped along with the flat panels which are attached to the cabinet frame.

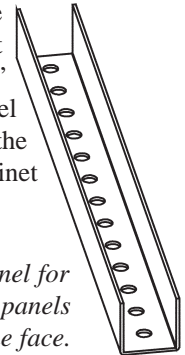

A "U" shaped channel for aligning flat 1/8" panels with frame face.

PANEL SHIMS For use with 1/8" Panels	
Height of Flat Panel	Part Number of Shim
1 3/4"	86-0112-02
3 1/2"	86-0312-02
5 1/4"	86-0512-02
7"	86-0712-02
8 3/4"	86-0812-02
10 1/2"	86-1012-02
12 1/4"	86-1212-02
14"	86-1412-02
15 3/4"	86-1512-02
17 1/2"	86-1712-02
19 1/4"	86-1912-02
21"	86-2112-02

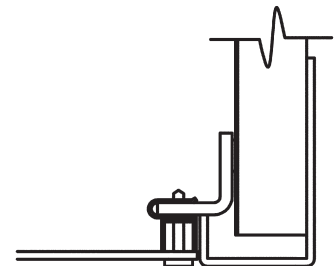

Panel Shim in place between flat panel and panel mounting angle

Product Features

- ▶ Constructed of 11-gauge steel
- ▶ Holes are on Universal E.I.A. Standard RS-310. Punched for Speed Nuts® or tapped 10-32 on face leg
- ▶ Edge-rolled to eliminate sharp edges

PANEL MOUNTING ANGLES			
Overall Height of Desk Assembly	Height of Panel Space	For Front or Rear Openings (plated)	
		Punched	Tapped
26"	21"	01-2101-02	01-2102-02
29"	22 3/4"	01-2201-02	01-2202-02
36"	29 3/4"	01-2901-02	01-2902-02
42"	36 3/4"	01-3601-02	01-3602-02



Equipment & Sliding Chassis Shelves Chassis Guides and Supports

Equipment Shelves

The Equipto Equipment Shelves are designed to provide a rugged support surface for heavy equipment. They are available plain or with a grill. The grilled area is 67% open, with rectangular openings 1/4" x 1 1/2", separated by a 3/32" web comprising most of the shelf area. Both plain and grilled shelves are formed of 16-gauge steel.

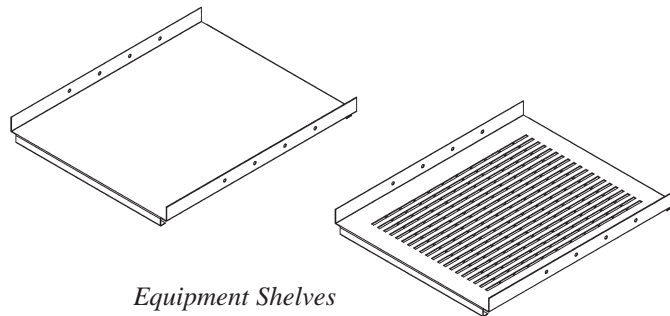

Equipment Shelves

Sliding Chassis Shelves

The Equipto Sliding Chassis Shelves are designed to provide easy access to chassis and other equipment. They are available plain or with a grill and are mounted on ball bearing slides with front disconnect. Both plain and grilled shelves are formed of 16-gauge steel.

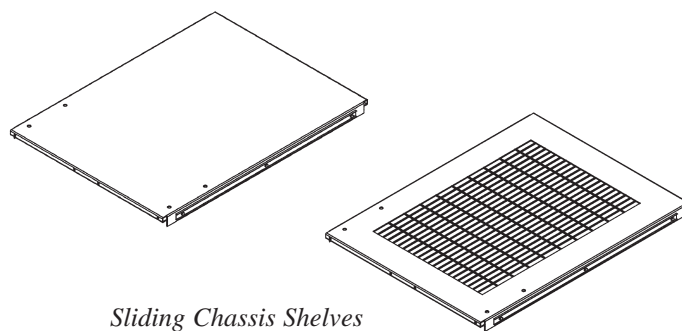

Sliding Chassis Shelves

Product Features

- ▶ Constructed of 16-gauge steel
- ▶ Available plain or grilled
- ▶ Available in 25 1/2" and 30 3/4" depths; 19" and 24" widths

Chassis Guides and Supports

The Equipto Chassis Guides and Supports are used to support and to guide heavily loaded chassis that must be moved into, or out of, a cabinet on an intermittent basis. The guide angle is adjustable from side-to-side to ensure alignment of the chassis with the panel opening to minimize possible damage to the chassis panel or to the cabinet face.

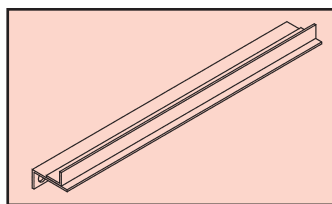

Product Features

- ▶ Support angle formed of 12-gauge steel
- ▶ Adjustable Guide angle formed of 16-gauge steel

CHASSIS GUIDES & SUPPORTS

Comp. Depth	Part Number
25 1/2"	15-0125-02
30 3/4"	15-0130-02
36"	15-0136-02

SLIDING CHASSIS SHELVES For Desk Assemblies		
Electronic Compartment Depth	Plain Shelf	Grilled Shelf
	Part No.	Part No.
For 19" wide panel space		
25 1/2"	13-1925-11	13-1925-21
30 3/4"	13-1930-11	13-1930-21
36"	13-1936-11	13-1936-21
For 24" wide panel space		
25 1/2"	13-2425-11	13-2425-21
30 3/4"	13-2430-11	13-2430-21
36"	13-2436-11	13-2436-21

EQUIPTO SHELVES For Desk Assemblies		
Electronic Compartment Depth	Plain Equipment Shelf	Grilled Equipment Shelf
	Part No.	Part No.
For 19" wide panel space		
25 1/2"	18-1925-01	18-1925-02
30 3/4"	18-1930-01	18-1930-02
36"	18-1936-01	18-1936-02
For 24" wide panel space		
25 1/2"	18-2425-01	18-2425-02
30 3/4"	18-2430-01	18-2430-02
36"	18-2436-01	18-2436-02

If mounting the shelf in a desk with tapped vertical mounting rails, then add a 'T' to the front of the P/N Ex: T13-1925-11